

Set Screws

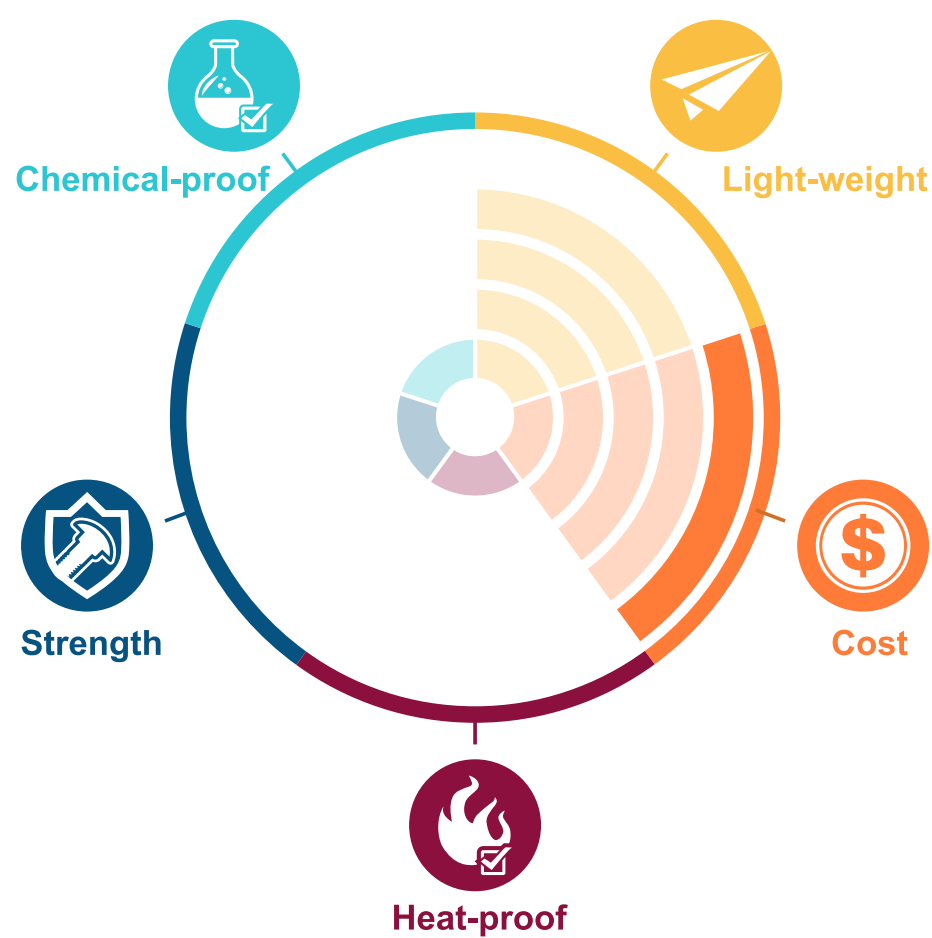

Model HSPA6M(-)(L)

PA6 Polyamide 6 / Engineering Plastics



PA6 should be used if a lightweight engineering plastic is required to withstand high impact and stress. It has better aesthetic appearance than PA 66 due to its lustrous finish and is easier to be dyed. It is an ideal choice for applications in the automotive, industrial and military industries. It is not ideal, however, for applications that are exposed to water at high temperatures due to its higher water absorption and lower heat deflection rate than PA 66.

Product Properties

1. High mechanical strength, stiffness, hardness and toughness.
2. Good fatigue resistance.
3. High mechanical damping ability.
4. Excellent wear resistance.
5. Good electrical insulating properties.

Applied industries



Specs

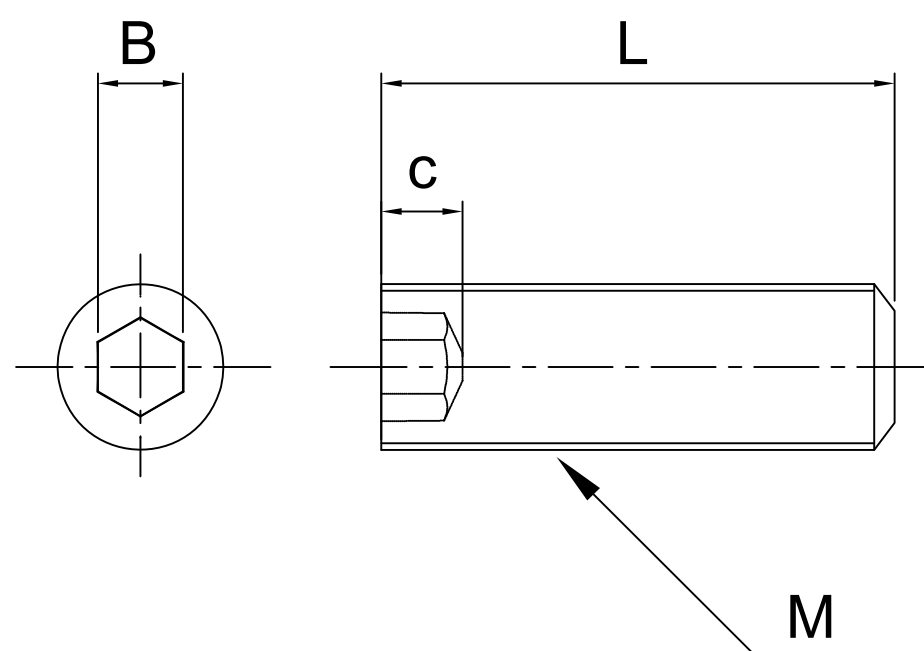

Model: HSPA6M(-)(L)

M	3	4	5	6	8
BxC	1.5x2	2x2.5	2.5x3	3x3.5	4x5
Pitch	0.5	0.7	0.8	1	1.25
L(mm)	4	•	-	-	-
	5	•	•	•	-
	6	•	•	•	•
	8	•	•	•	•
	10	•	•	•	•
	12	•	•	•	•
	15	•	•	•	•
	20	-	•	•	•
	25	-	-	-	•
30	-	-	-	-	•

Contact Information

No.60-3, Dongqi 7th Ln., Lukang Township, Changhua County 505008, Taiwan.
 TEL: +886-4-778-4688
 FAX: +886-4-778-4268
 E-mail: sales@plasautotw.com

