

Set Screws

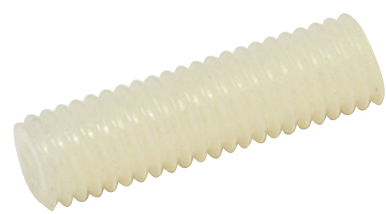

Model HSPAM(-)(L)

PA66 Polyamide 66 / Engineering Plastics

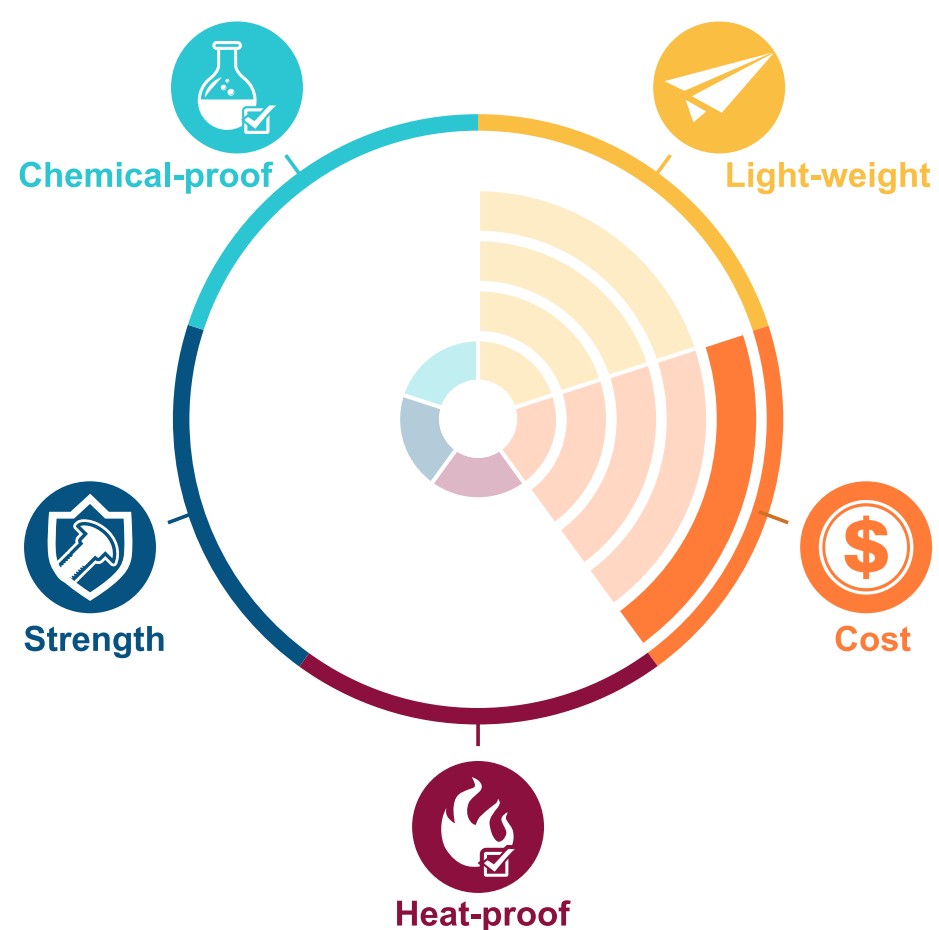

Nylon 66 should be used if a part is required to be exposed to higher temperatures. Additionally, its stiffness and good tensile and flexural modulus make it an ideal material for applications that need a long-term repeating working condition. Typical application parts include: friction bearings, radiator caps and tire ropes.

Product Properties (compared to PA6)

1. Slightly less moisture absorption ability.
2. Better wear resistance.
3. Better chemical resistance to acids.
4. Higher heat deflection temperature.

Applied industries



Specs

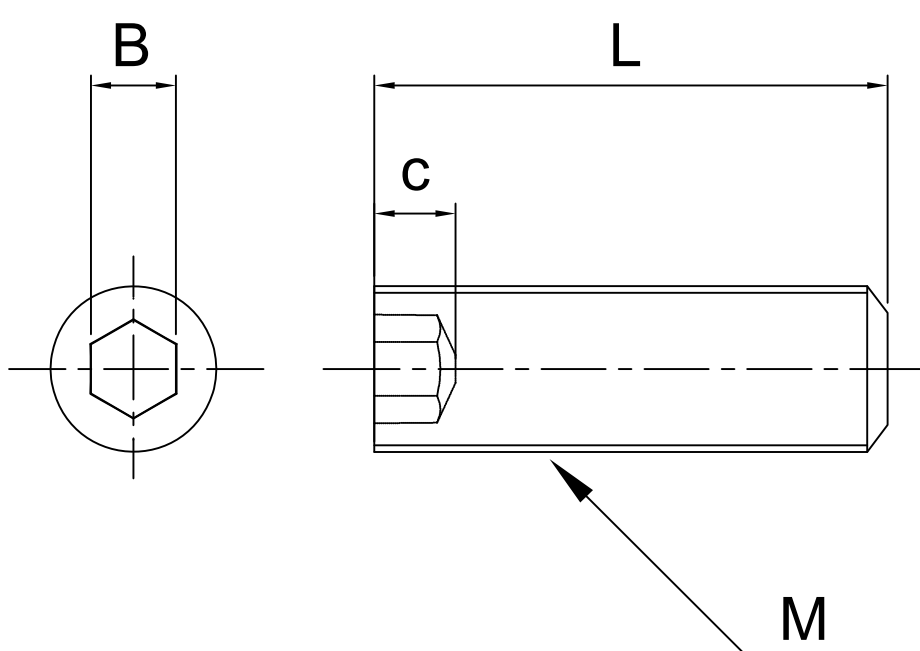

Model: HSPAM(-)(L)

M	3	4	5	6	8
BxC	1.5x2	2x2.5	2.5x3	3x3.5	4x5
Pitch	0.5	0.7	0.8	1	1.25
L(mm)	4	•	-	-	-
	5	•	•	•	-
	6	•	•	•	•
	8	•	•	•	•
	10	•	•	•	•
	12	•	•	•	•
	15	•	•	•	•
	20	-	•	•	•
	25	-	-	-	•
30	-	-	-	-	•

Contact Information

No.60-3, Dongqi 7th Ln., Lukang Township, Changhua County 505008, Taiwan.
 TEL: +886-4-778-4688
 FAX: +886-4-778-4268
 E-mail: sales@plasautotw.com

